

**SAN ANTONIO WATER SYSTEM PURCHASING DEPARTMENT**

---

Issued By: **D. Anthony Rubin**  
BID NO.: **16-16036**

Date Issued: **April 18, 2016**

---

**FORMAL INVITATION FOR BIDS FOR THE PURCHASE OF THREE (3) MECHANICALLY  
CLEANED BAR SCREENS WITH MULTIPLE RAKE BLADES AND ONE (1) SCREENINGS  
WASHER COMPACTOR FOR SALADO CREEK WRC – ADDENDUM 1**

---

Sealed bids addressed to the Purchasing Director, San Antonio Water System, 2800 US Hwy 281 North, Administration Bldg., 5<sup>th</sup> Floor, San Antonio, TX 78212 will be received until **3:00 p.m. April 29, 2016** and then publicly opened and read aloud for furnishing materials or services as described herein below,

The San Antonio Water System Purchasing Department is willing to assist any bidder(s) in the interpretation of bid provisions or explanation of how bid forms are to be completed. Assistance may be received by visiting the Purchasing Office in the SAWS Main Office, 2800 US Hwy 281 North, San Antonio, TX 78212, or by calling (210) 233-3819.

This invitation includes the following:

Invitation for Bids  
Terms and Conditions of Invitation for Bids

Specifications and General Requirements  
Price Schedule

The undersigned, by his/her signature, represents that he/she is authorized to bind the Bidder to fully comply with the Specifications and General Requirements for the amount(s) shown on the accompanying bid sheet(s). By signing below, Bidder has read the entire document and agreed to the terms therein.

Signer's Name: \_\_\_\_\_ Firm Name: \_\_\_\_\_  
(Please Print or Type)

Address: \_\_\_\_\_

Signature of Person Authorized to Sign Bid \_\_\_\_\_ City, State, Zip Code: \_\_\_\_\_

Email Address: \_\_\_\_\_ Telephone No.: \_\_\_\_\_

Fax No.: \_\_\_\_\_

Please complete the following:

Prompt Payment Discount: \_\_\_\_\_% \_\_\_\_\_days. (If no discount is offered, Net 30 will apply.)

Please check the following blanks which apply to your company:

Ownership of firm (51% or more):

Non-minority  Hispanic  African-American  Other Minority (specify) \_\_\_\_\_

Female Owned  Handicapped Owned  Small Business (less than \$1 million annual receipts or 100 employees)

Indicate Status:  Partnership  Corporation  Sole Proprietorship  Other (specify) \_\_\_\_\_

Tax Identification Number: \_\_\_\_\_

**To report suspected ethics violations impacting the San Antonio Water System, please call 1-800-687-1918.**

---

This **Addendum 1** is issued to make changes as documented herein to the original bid sent to you on April 5, 2016. All other requirements, terms and conditions of the original bid remain the same.

### **Revisions to Terms and Conditions**

The bid closing date is being extended. Bids will be received until **3:00 p.m., April 29, 2016.**

### **Revisions to Specifications**

**Under STANDARD REQUIREMENTS, No. 7 on Page 12 of 49,** Add the following at the end of the paragraph:

“The deadline for questions is **3:00 PM Monday April 25, 2016.**”

**Under STANDARD REQUIREMENTS Section on Page 13 of 49,** add the following paragraph:

- “ 15. The supplier must submit with their bid any required structural, electrical, and/or mechanical changes required to accommodate the proposed equipment. This includes modifications to the existing screenings conveyor to accept the new screens and compactor. Bids including proposed equipment that require excessive modifications may be rejected. The San Antonio Water System is the sole and final judge as to whether the proposed changes are excessive.”

**Under Section 1.1 on Page 14 of 49,** add the following paragraph:

- “ H. The supplier must submit with their bid any required structural, electrical, and/or mechanical changes required to accommodate the proposed equipment. This includes modifications to the existing screenings conveyor to accept the new screens and compactor. **Bids including proposed equipment that require excessive modifications may be rejected. The San Antonio Water System is the sole and final judge as to whether the proposed changes are excessive.**”

**Under Section 1.6.N.1 on Page 17 of 49,** Replace the last sentence with the following:

“The technician shall be an employee of the screen manufacturer.”

**Under Section 2.4 A.1, on Page 20 of 49,** change 11 cubic feet to 17 cubic feet. Paragraph should read as follows:

- “1. Each screen shall be capable of handling the **17 cubic feet** of wet uncompacted screenings per 1 million gallons (17 CF/MG) of raw unscreened wastewater that passes through it.”

**Under Section 2.6.B.3, on Page 21 of 49,** replace 6” with 8” in the fourth sentence. The fourth sentence should read as follows:

“The bars shall extend from the channel floor to a minimum **8”** above the maximum water level.”

**Under Section 2.11.A.6, on Page 31 of 49,** remove paragraph 6 in its entirety.

**Under Section 2.11.D.5, on Page 33 of 49,** replace the paragraph in its entirety with the following:

- “5. In addition, the following devices shall be included in the main control panel for the new compactor and existing conveyor:”

**Under Attachment A, Photo 6, on Page 42 of 49-** See revised Existing Washer/Compactor attachment with support dimensions, see Attachment A Photo 6 Revised.

**Under Attachment B, Figure 2, on Page 46 of 49-** See revised existing Washer/Compactor height dimension on attached revised Attachment B, Figure 2, Revised.

### **Questions / Requested Clarifications**

1. Will the bidder be required to explain to SAWS with their bid any required site modifications to install their proposed screen and washer/compactor?  
**SAWS Response:** Yes. See additional language included in Addendum 1 in the Standard Requirements and Paragraph 1.1.
2. Will SAWS review these required site modifications and consider this work, by SAWS personnel, in the overall evaluation to select the winning bid?  
**SAWS Response:** Yes. See additional language included in Addendum 1 in the Standard Requirements and Paragraph 1.1.
3. Will the selection be based purely on screen, washer/compactor and control panel costs alone?  
**SAWS Response:** The bid will be awarded to the lowest responsible bidder. If the low bidder proposes equipment that requires excessive modifications, SAWS can reject the bidder and go with the next lowest responsible bidder. See additional language included in Addendum 1 in the Standard Requirements and Paragraph 1.1.
4. **Sub Section: 2.6.B.6.** - There is conflict for requirements of minimum bar length between sections 2.6.B.3. and 2.6.B.6.  
**SAWS Response:** See revision for Paragraph 2.6.B.3 above.
5. **Sub Section: 2.11.A.6** - There is conflict for requirements listed in 2.11.A.6 and 2.11.A.1  
Per 2.11.A.6- Type 304 stainless steel enclosure together with a local push button station for each screen rated for a NEMA 7, Class 1 Division 2 environment.  
Per 2.11.A.1 single main control panel shall be furnished with a lockable NEMA 4X corrosion-resistant Type 316 stainless steel enclosure together with a local push button station for each screen rated for a NE1V1A 7, Class I Division 2 environment.  
**SAWS Response:** See revision for Paragraph 2.11.A.6 above.

**IT IS NECESSARY TO RETURN THIS ADDENDUM TOGETHER WITH YOUR BID.**

**ATTACHMENT A Photo 6 REVISED – Existing Washer Compactor**

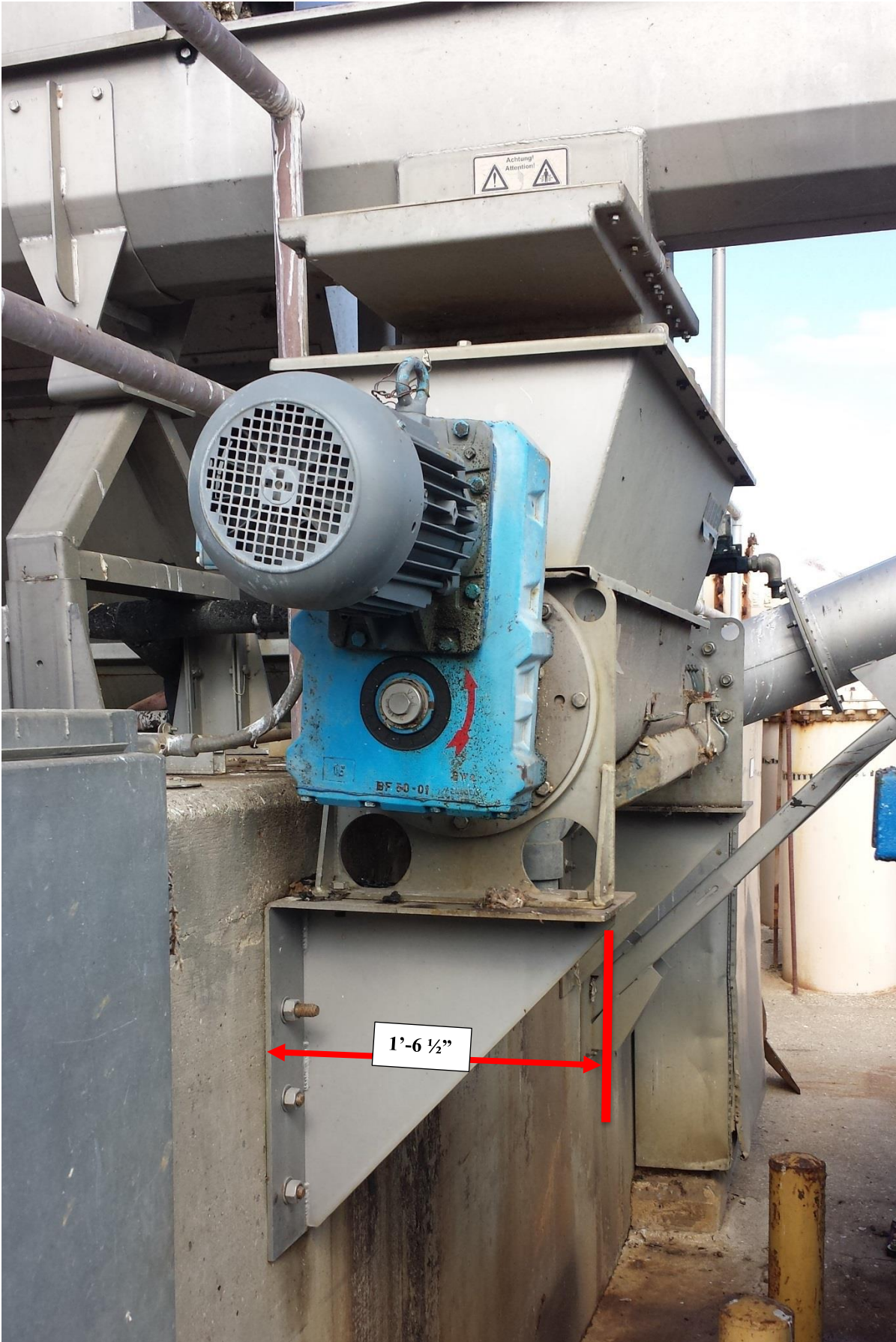

**ATTACHMENT B REVISED**

**Figure 2— Existing Washer Compactor - As-Built Shop Drawings**

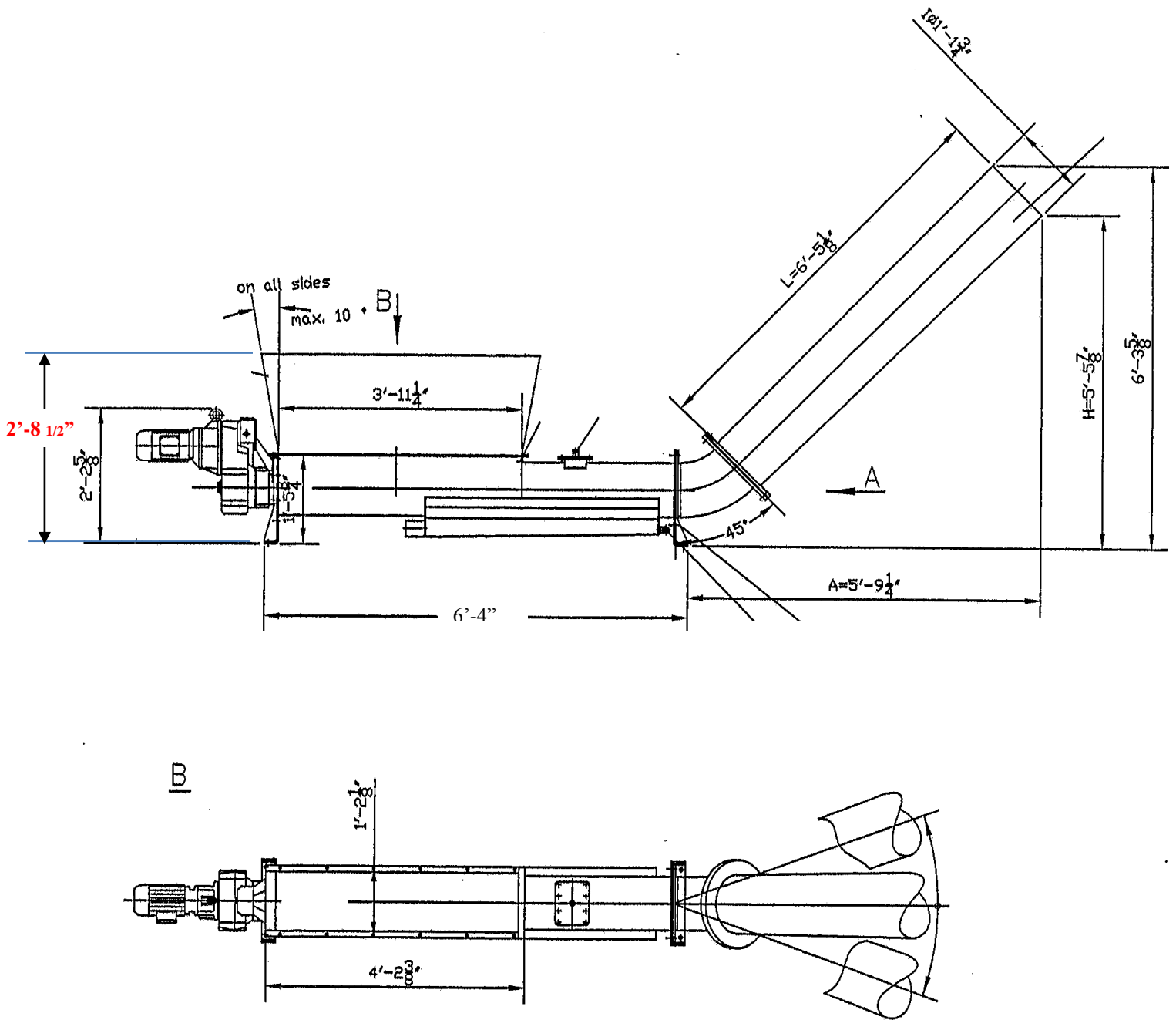

**IT IS NECESSARY** TO RETURN THIS ADDENDUM TOGETHER WITH YOUR BID.